

RHINOCEROS

XN28

CRAWLER EXCAVATOR

SPECIFICATION			
Operating weight	kg	2610/2580	
Bucket capacity	m ³	0.04	
Type		backhoe	
Engine	Brand	YANMAR/KUBOTA	
	Displacement	L	1.267/1.123
	rated power	kw	14.6/14.2
	Max. Torque	N.m	51.9/5.13
	Starter	V-kW	12-1.4
	generator	V-A	12-55
	Accumulator	V-Ah	12-45, CCA433
Speed and digging force	Traveling speed	km/h	high: 2.7; low: 1.4
	Rotating speed	rpm	9
	Gradeability		30°
	Bucket digging force	kN	16.14
	Arm digging force	kN	11.7
Track parts	Max. traction	kN	13
	Ground pressure	kPa	36
	Track material		rubber/steel
	Tensioner		grease cylinder
	Pump type		plunger pump
	Working pressure	Mpa	22
	Flow rate	L/min	61.9
	Hydraulic oil tank capacity	L	25.3
	Engine oil capacity	L	3.4 (1.6)
	Fuel tank capacity	L	22

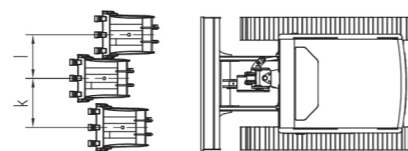
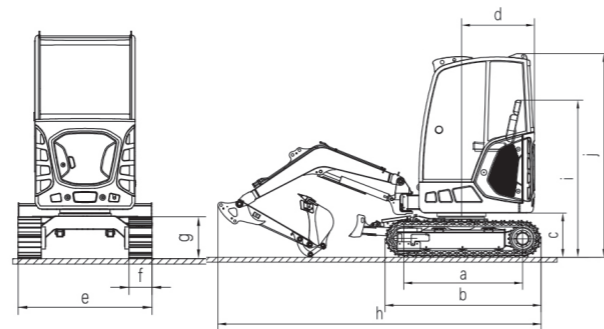

Main dimensions schematic diagram

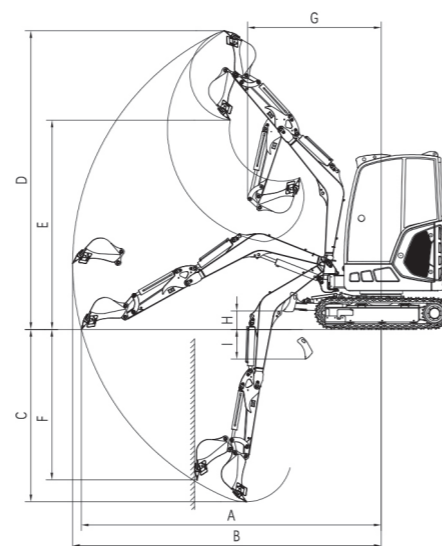

Working range schematic diagram

OPERATING RANGE			
A	Max. ground digging radius	mm	4168
B	Max. digging radius	mm	4290
C	Max. digging depth	mm	2396
D	Max. digging height	mm	4153
E	Max. dumping height	mm	2909
F	Max. vertical digging depth	mm	2093
G	Min. rotating radius	mm	1857
H	Max. lifting height of the bulldozer	mm	257
I	Max. digging depth of the bulldozer	mm	413

MAIN DIMENSIONS			
a	Wheel base	mm	1440
b	Track total length	mm	1892
c	Platform ground clearance	mm	535
d	Rotation radius	mm	885
e	Chassis width	mm	1454
f	Track width	mm	250
g	Track height	mm	455
h	Transportation length	mm	3918
i	Seat height	mm	1904
j	Overall height	mm	2469
k	Boom swing left	mm	539
l	Boom swing right	mm	477

SHANDONG KEN STONE HEAVY MACHINERY CO.,LTD



Address : Dingyuanzhai Industrial Park, Guan County, Liaocheng city, Shandong Province, China
 Hotline : 0086-635-8362550
 Postal code : 252512
 Website : www.rhinoexcavator.com
 E-mail : office@sdxiniu.com

Factory visit



We reserve the right to improve or withdraw the specification or products without prior notice.

XN28 CRAWLER EXCAVATOR