

RHINOCEROS

XN20EV

ELECTRIC EXCAVATOR

OPERATING RANGE

A	Max.digging radius on ground	3500mm
B	Max.digging radius	3580mm
C	Max. digging depth	2150mm
D	Max. digging height	3275mm
E	Max. dumping height	2310mm
F	Max. vertical digging depth	1740mm
G	Min. swing radius	1440mm
H	Max. blade lifting height	275mm
I	Max. blade lifting depth	180mm

SPECIFICATION

Operating weight	2000kg	
Working device form	Backhoe	
Standard bucket capacity	0.045 cbm	
Electric motor	Model No.	TZXQD112-6
	Rated power	5KW/6.7HP
	Rated speed	1500rpm
	Rated torque	31.8N.m
Speed and digging force	Max.travel speed	3 km/h
	Swing speed	11 rpm
	Max . gradeability	30°
	Bucket digging force	10.5KN
	Arm digging force	6.5KN
Ground pressure	40KPa	
	Track material	Rubber
Hydraulic and liquid capacity	Pump type	Piston pump
	Pressure	25MPa
	Flow rate	27L/min
	Hydraulic oil tank capacity	15L
Battery	Battery capacity	35.3kwh

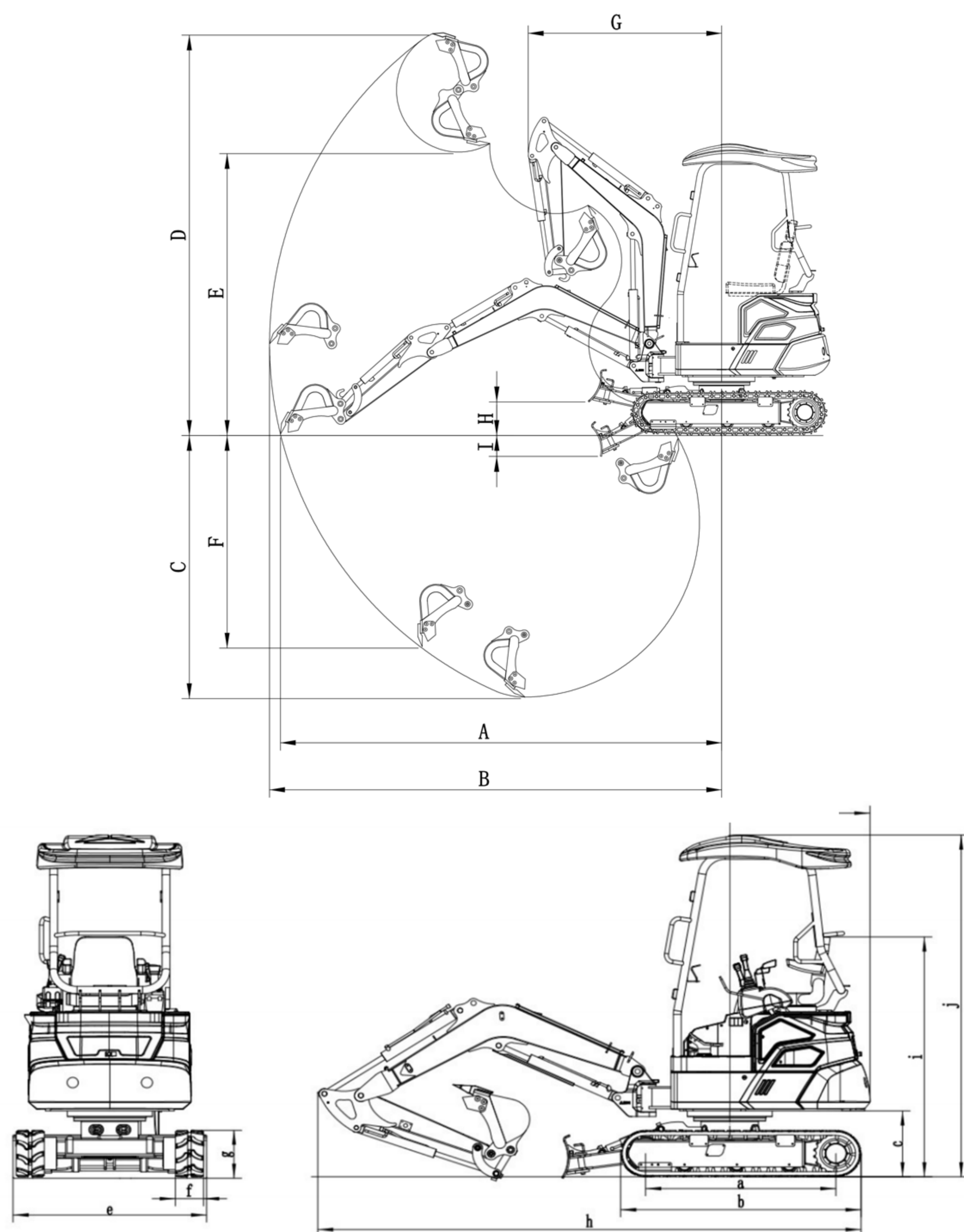

MAIN DIMENSIONS

a	Total length	1219mm
b	Total height	1540mm
c	Counter weight turning radius	453mm
d	Tail swing radius	900mm
e	Chassis width	900(1240)mm
f	Track width	230mm
g	Track height	320mm
h	Transport length	3540mm
i	Seat to ground height	1660mm
j	Overall height	2360mm

www.rhinoexcavator.com



SHANDONG KEN STONE HEAVY MACHINERY CO.,LTD



Address : Dingyuanzhai Industrial Park,Guan County,Liaocheng city, Shandong Province, China
 Postal code : 252512
 Website : www.rhinoexcavator.com
 E-mail : office@sdxiniu.com

Factory visit

XN20EV

ELECTRIC EXCAVATOR