

# RHINOCEROS

## MY660

### CRAWLER EXCAVATOR

#### SPECIFICATION

Machine weight	635kg	
Working device form	Backhoe	
Standard bucket capacity	0.018 cbm	
ENGINE	Model No.	DUCAR 270CC
	Displacement	2700CC
	Rated power	6 kw/3600
	Max. torque	17.7 N.m/2500
Speed and digging force	Max. travel speed	2.5 km/h
	Swing speed	8.5 rpm
	Max. gradeability	30°
Track material	Rubber	
Hydraulic and liquid capacity	Pump type	Gear pump
	Work pressure	16 MPa
	Flow rate	19.5L/min
	Hydraulic oil tank capacity	12 L
	Fuel tank capacity	6 L

#### OPERATING RANGE

A	Max. digging radius on ground	2250mm
B	Max. digging radius	2342mm
C	Max. digging depth	1250mm
D	Max. digging height	2107mm
E	Max. dumping height	1442mm
F	Max. vertical digging depth	350mm
G	Min. swing radius	1112mm
H	Max. blade lifting height	96mm
I	Max. blade lifting depth	116mm

#### MAIN DIMENSIONS

a	Wheel base	807mm
b	Track length	1117mm
c	Upper chassis ground clearance	406mm
d	Counterweight turning radius	730mm
e	Chassis width	700mm
f	Track width	150mm
g	Track height	320mm
h	Transportation length	2170/2785mm
i	Height of seat to ground	1390mm
j	Total height	1711mm
m	Boom swing-left	48°
n	Boom swing-right	48°

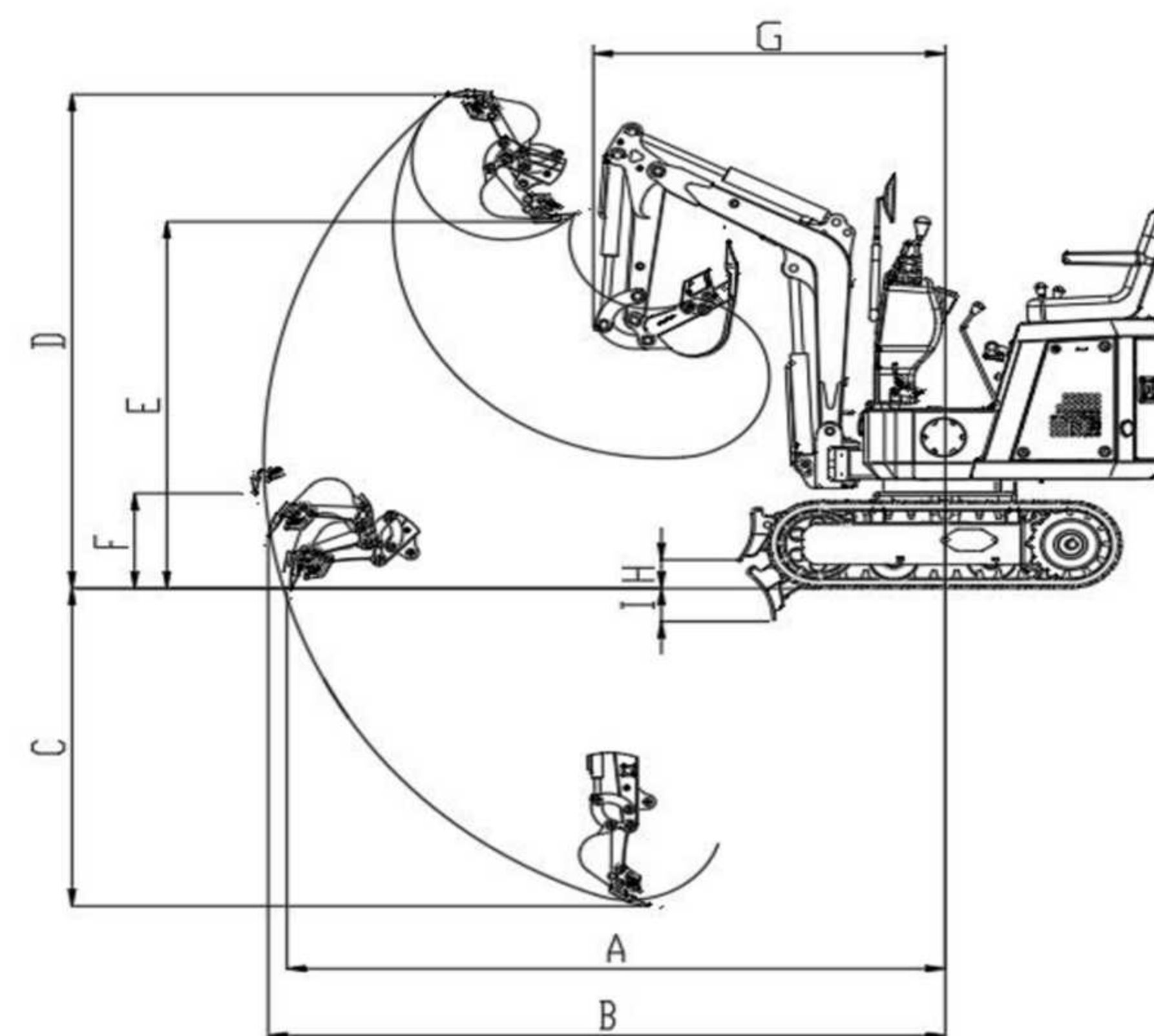
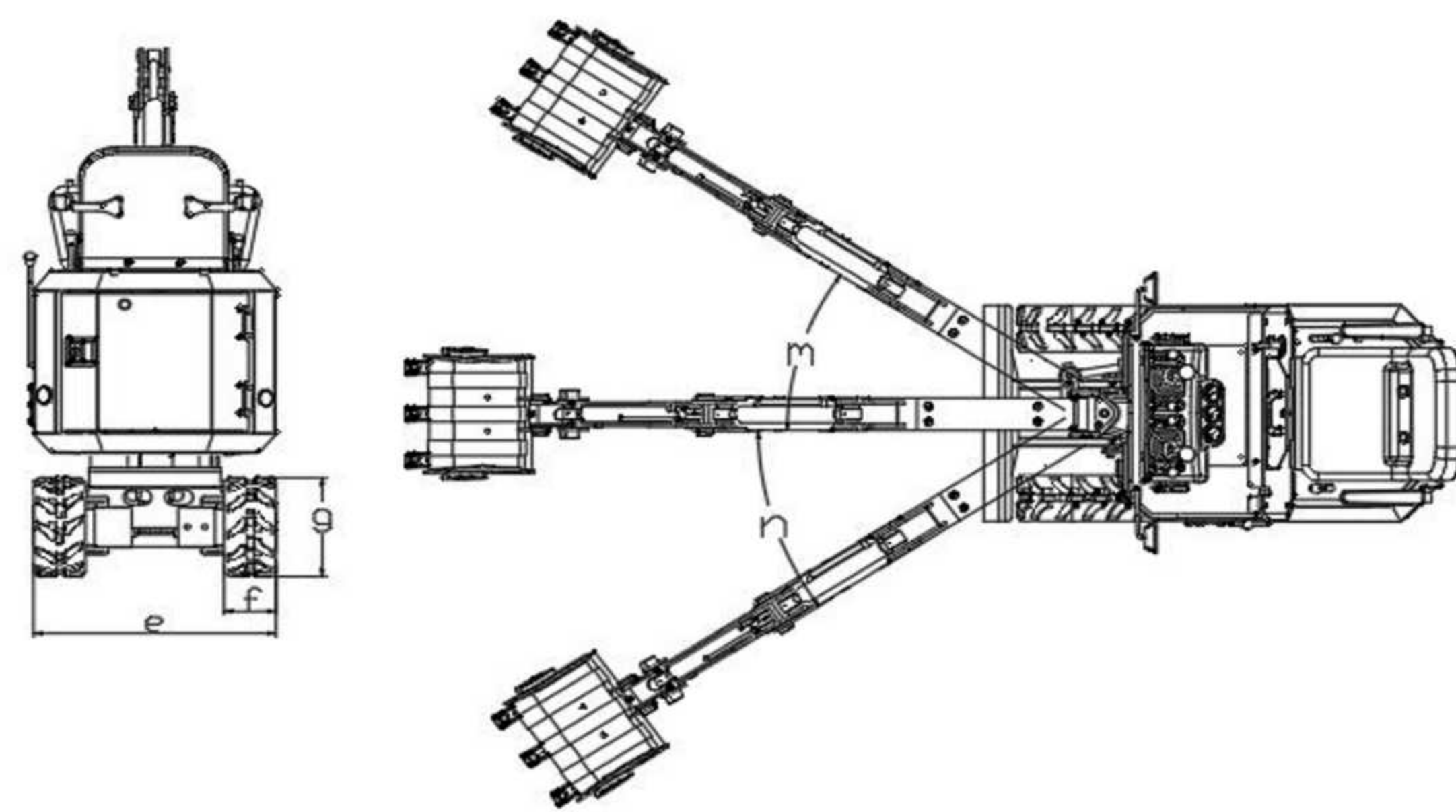
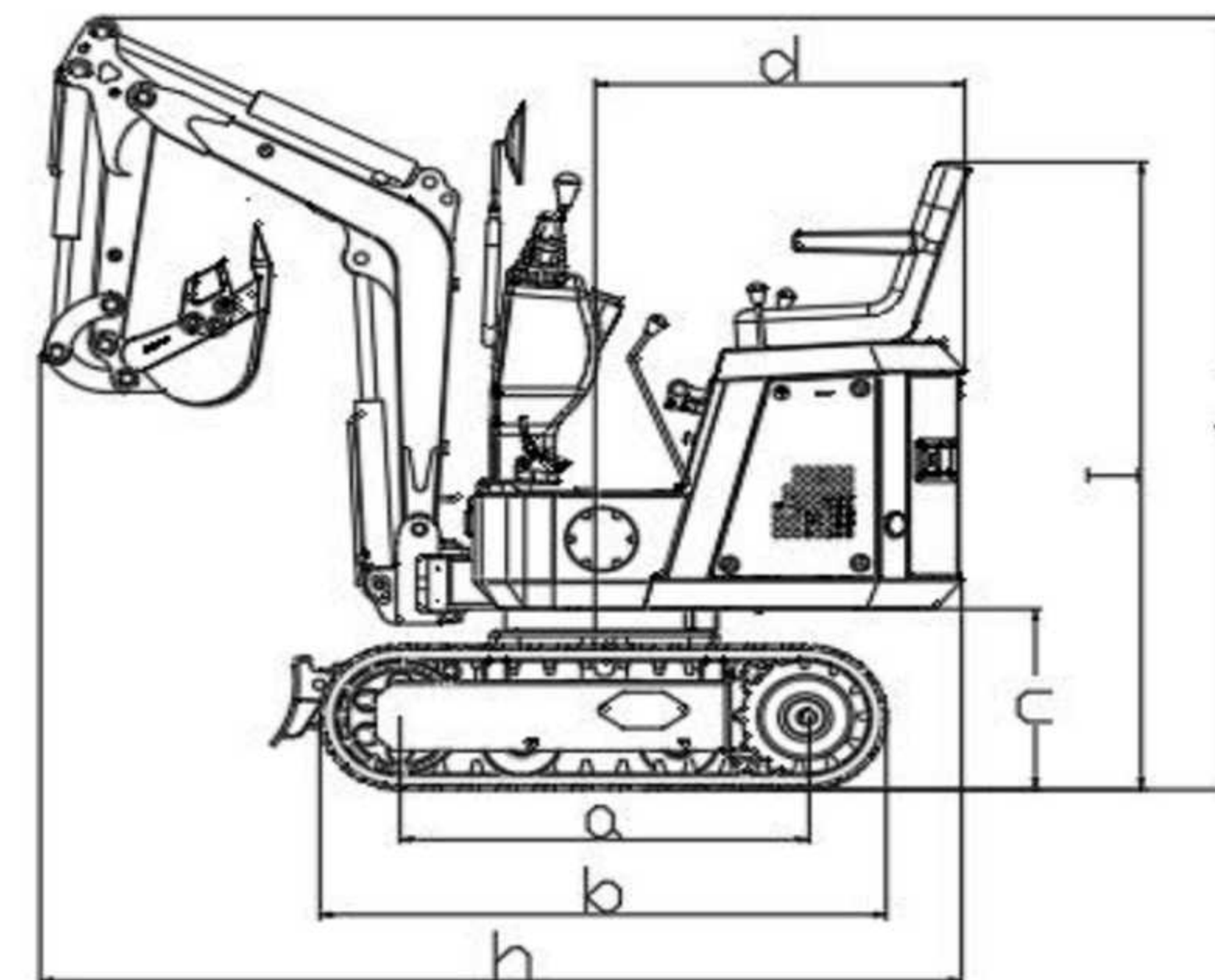

[www.rhinoexcavator.com](http://www.rhinoexcavator.com)



SHANDONG KEN STONE HEAVY MACHINERY CO.,LTD



Address : Dingyuanzhai Industrial Park, Guan County, Liaocheng city, Shandong Province, China  
 Postal code : 252512  
 Website : [www.rhinoexcavator.com](http://www.rhinoexcavator.com)  
 E-mail : [office@sdxiniu.com](mailto:office@sdxiniu.com)

Factory visit

## MY660 CRAWLER EXCAVATOR