

RHINOCEROS

X9

WHEEL-CRAWLER EXCAVATOR

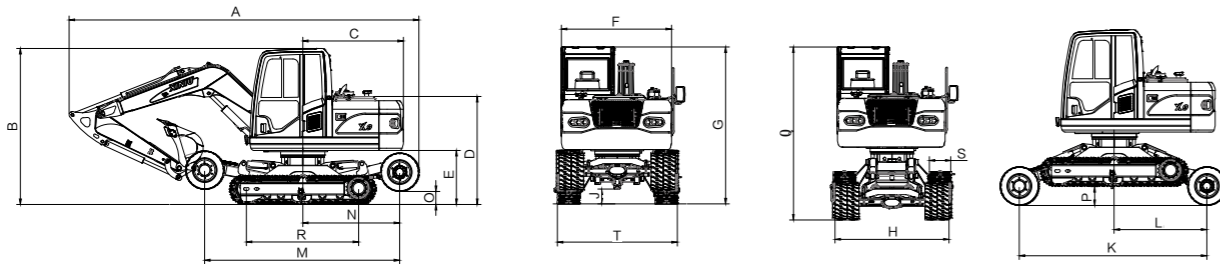

MAIN DIMENSION		
A	Total length(Boom3.5m+arm2m)	6570mm
B	Total height(Boom3.5m+arm2m)	2982mm
C	Counter weight turning radius	1836mm
D	Engine hood height	2104mm
E	Counter weight ground clearance	1120mm
F	Upper structure width	2000mm
G	Cabin height (wheels up)	2982mm
H	Tire width	2120mm
J	Minimum ground clearance	270mm
K	Wheels up wheel gauge	3400mm
L	Distance of swing center to rear wheel (wheels down)	1682mm
M	Wheels down wheel gauge	3560mm
N	Distance of swing center to rear wheel (wheels up)	1767mm
O	Rear wheel ground clearance (wheels up)	300mm
P	Tracks ground clearance (wheels down)	330mm
Q	Total height (wheels down)	3190mm
R	Track wheel base	2050mm
S	Track width	400mm
T	Track outer width	2160mm

SPECIFICATION		
Operating weight	8960kg	
Bucket capacity	0.3m ³	
Engine	Brand	Yanmar 4TNV98-ZCSLK
	Displacement	3.319L
	Engine power/rpm	46.3kW/2200 rpm
	Max. torque	223.3 ~ 243.5N.m/1600 ± 100rpm
Speed	Wheel travelling speed	21km/h
	Track travelling speed	3km/h
	Swing speed	9rpm
	Max. grade ability	30°
Hydraulic and liquid capacity	Hydraulic system	Rexroth
	Pump	Variable pump
	Pressure	25MPa
	Displacement	132L/min
	Hydraulic oil tank capacity	175L
	Fuel tank capacity	150L
	Engine oil capacity	12L

OPERATING RANGE		
Working device	Boom 3.5m+Arm 2m	
A1	Max. digging radius	6680mm
A	Max. digging radius on ground	6555mm
B	Max. digging depth	3572mm
C	Max. Cutting height	6955mm
D	Max. dumping height	5245mm
E	Min. turning radius	2540mm
F	Max. vertical digging depth	3255mm
Bucket digging force (Kn)		56
Bucket arm digging force (Kn)		36

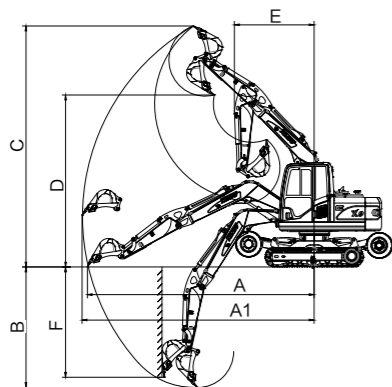

SHANDONG KEN STONE HEAVY MACHINERY CO.,LTD



Address : Dingyuanzhai Industrial Park, Guan County, Liaocheng city, Shandong Province, China
 Hotline : 0086-635-8362550
 Postal code : 252512
 Website : www.rhinoexcavator.com
 E-mail : office@sdxiniu.com

Factory visit



We reserve the right to improve or withdraw the specification or products without prior notice.

X9

WHEEL-CRAWLER EXCAVATOR